



FIREX 2S



- Class 5 EN 303-5:2012
- High efficiency: 89,5%
- Autonomy up to 6 hours
- Reversed flame combustion
- Loading door opening 180°
- Tray, grate and fire bars in stainless steel AISI 310S
- Precision butterfly air registers
- Safety heat exchanger



TOTAL GASIFICATION WOOD FIRED BOILER, WITH DOWNWARD REVERSED FLAME AND THERMO-CONTROLLED PYROLYTIC COMBUSTION, WITH FAN POSITIONED IN THE SUCTION SIDE

OUTPUT RANGE	from 34 to 55 kW		
RETURN TEMPERATURE	> 55°C		
SUPPLY	wood logs		
MODELS	34	45	55
SEASONAL EFFICIENCY	 A+	 A+	 A+

boiler body in carbon steel – smoke circuit with reversed flame

Details

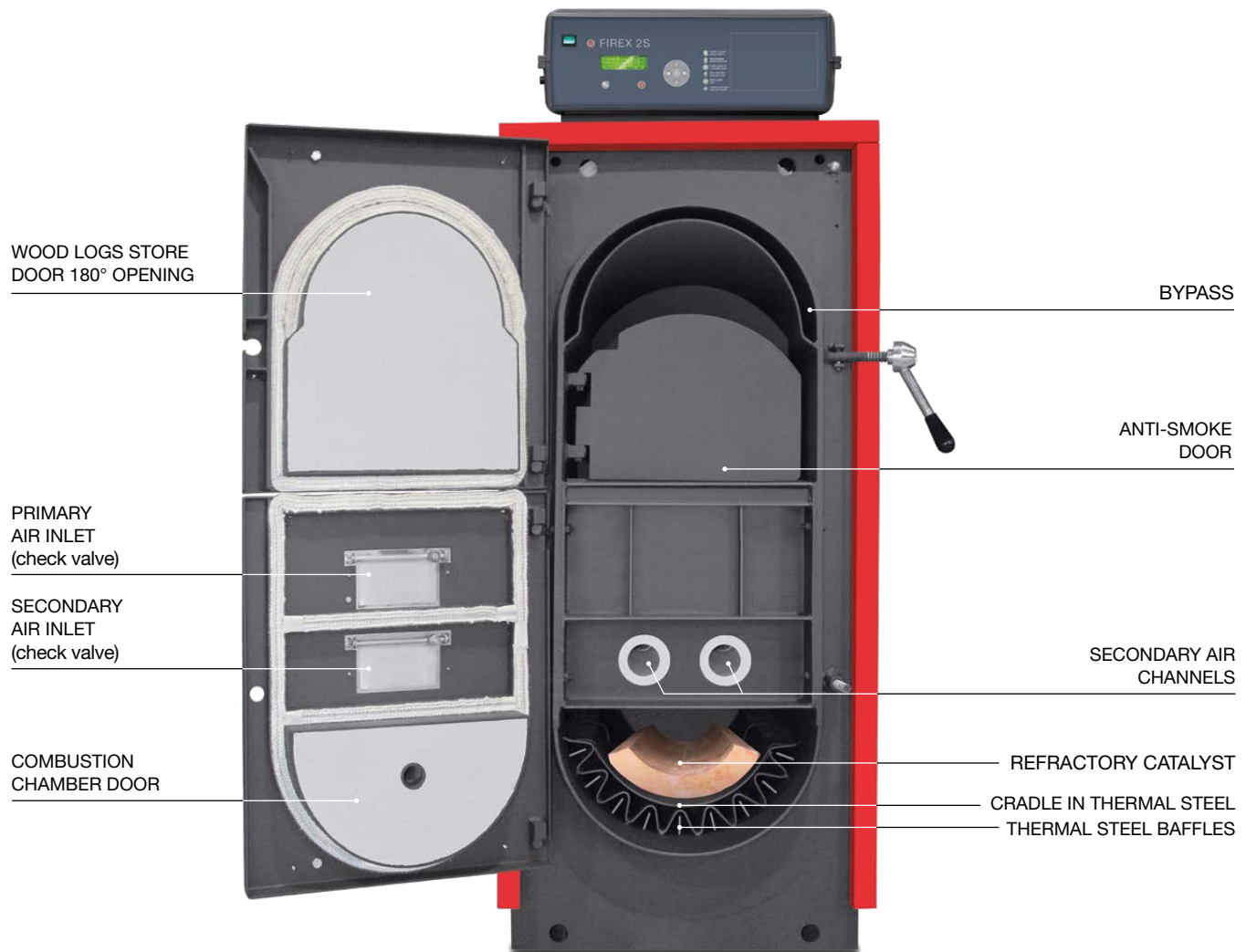

- Reversed flame combustion
- High efficiency (for the solid fuels): higher than 89,5%
- Regulation of primary and secondary air for the optimization and control of the combustion through butterfly adjusters with incorporated check valves
- Modulating fan on suction side
- Tray, grate and fire bars in stainless steel AISI 310S
- Rear internal wall in refractory material to avoid the possibility of the formation of condensates
- Catalyst in refractory stone
- Loading and maintenance of the wood storage room through front insulated upper door. The lower door, with a rotating angle of 180° gives access to the combustion chamber.
- Door opening handle with anti-scorch protection
- An internal door, placed between the loading door and the wood storage room acts as anti-smoke protection
- Wood storage room with walls 8 mm thick
- Boiler body and smoke chamber insulated with anti-tearing rock wool mattress (50 mm thick) and sheet of overlapped aluminum
- Panel board Biotronic for the automatic control of boiler fan and of the different types of installations, such as:
 - only heating
 - heating and DHW production through single coil or double coil or Tank in Tank type accumulator
 - in combination with thermal solar
- Anti-overheating safety heat exchanger, constituted by a steel coil, immersed directly in the water in the upper part of the boiler

Power and safety

Unical introduces **the FIREX 2S range** in answer to the increasing call for firewood boilers that use renewable resources.

A wood log fired boiler with charming aesthetics, coupled with several innovative technological solutions:

- **3 models** with power of **34, 45 and 55 kW**
- **Total gasification with pyrolytic combustion**

Operation

- The fan placed on the suction side ensures the optimization of consumption
- The materials, that must resist to fire and corrosion, are carefully selected
- Wisely insulated, despite its simplicity, it provides excellent thermal performance with reduced heat losses
- Dry combustion chamber with catalyst in refractory material for clean combustion. Smoke passages through triangular section channels, with transversal cuts (patented system), that absorb thermal expansion, so to eliminate mechanical stresses on the structure for the benefit of greater guarantee and durability over time
- Adjustable stainless steel baffles, inside the smoke channels, optimize heat exchange to increase efficiency
- Internal rear wall completely dry, in high-thickness refractory material for a long life, to the advantage of a rapid attainment of the steady state in the most critical phase, which is the ignition
- Fully insulated smoke chamber to reduce heat losses.

Practicality and ease of use

- **“Anti-smoke by-pass”** on the upper door.
- **Loading and maintenance of the wood store made easier, both**, by the insulated frontal loading door and by the one of the combustion chamber, thanks to the complete 180° opening.
- **Fast, easy opening and closing of the fire door**, thanks to the rotating knob and the comfortable insulated handle.

Autonomy

The rather small dimensions, for the category, thanks to the careful study of the internal volumes, facilitate its installation and, at the same time, allow its wood storage to contain 0.5 m long wood logs for the 34-45 kW versions; and 0.7 m for the 55 kW version, ensuring long operating ranges with few periodic refills.

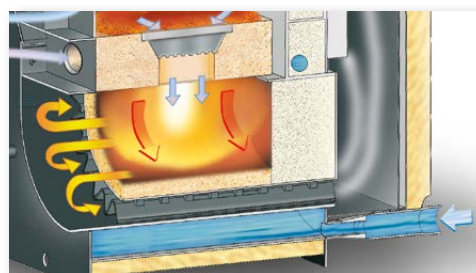

Dry, inverted flame, combustion chamber.

The details of BIOTRONIC

The standard supplied digital electronic panel board BIOTRONIC, adjusts and controls constantly the generated output.

The software of management constantly supervises all the states of the boiler operation and guarantees elevated safety levels giving a sound alarm in case of over temperature or defective temperature sensor and fuel commutation. It furnishes, besides, some visual messages: door open, inertial accumulator over the limit temperature, alarm for too high temperature in the

solar panels (if there), C.H. flow temperature sensor not operating.

- It is possible to monitor the temperature control of the inertial accumulator, of the D.H.W. storage tank, of the possible solar installation and of the anti-condensing system.
- The microprocessor regulator totally manages, and in automatic: the modulation of the flame, the ignition, the turning off and the operation of the burner.

Key:

- 1 Main switch
- 2 Control unit reset key
- 3 Summer / winter key
- 4 Fan start key
- 5 Key to change priority domestic hot water/heating
- 6 Boiler functions adjustment menu key
- 7 Functions value decrease key
- 8 Sound alarm acknowledge
- 9 Solar panel pump start indicator
- 10 Indicator storage tank
- 11 Heating pump start indicator
- 12 Auxiliary 230V
- 13 Fan start indicator
- 14 Auxiliary boiler start indicator oil/gas

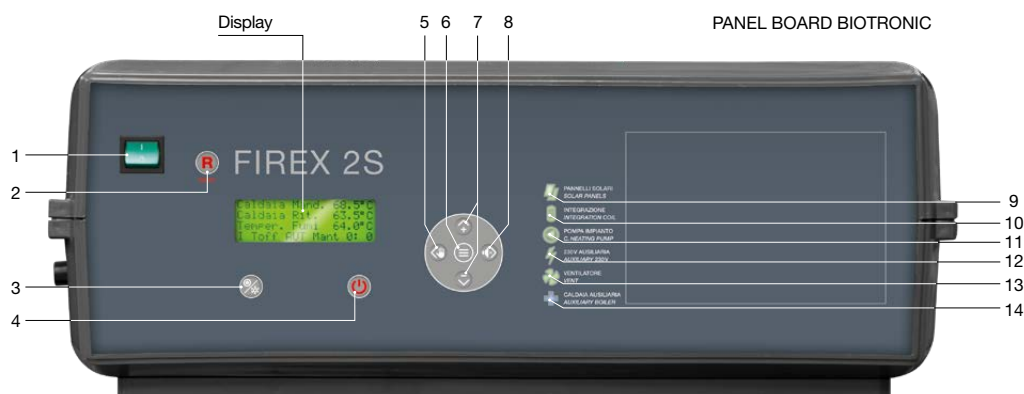

Dimensions and technical data

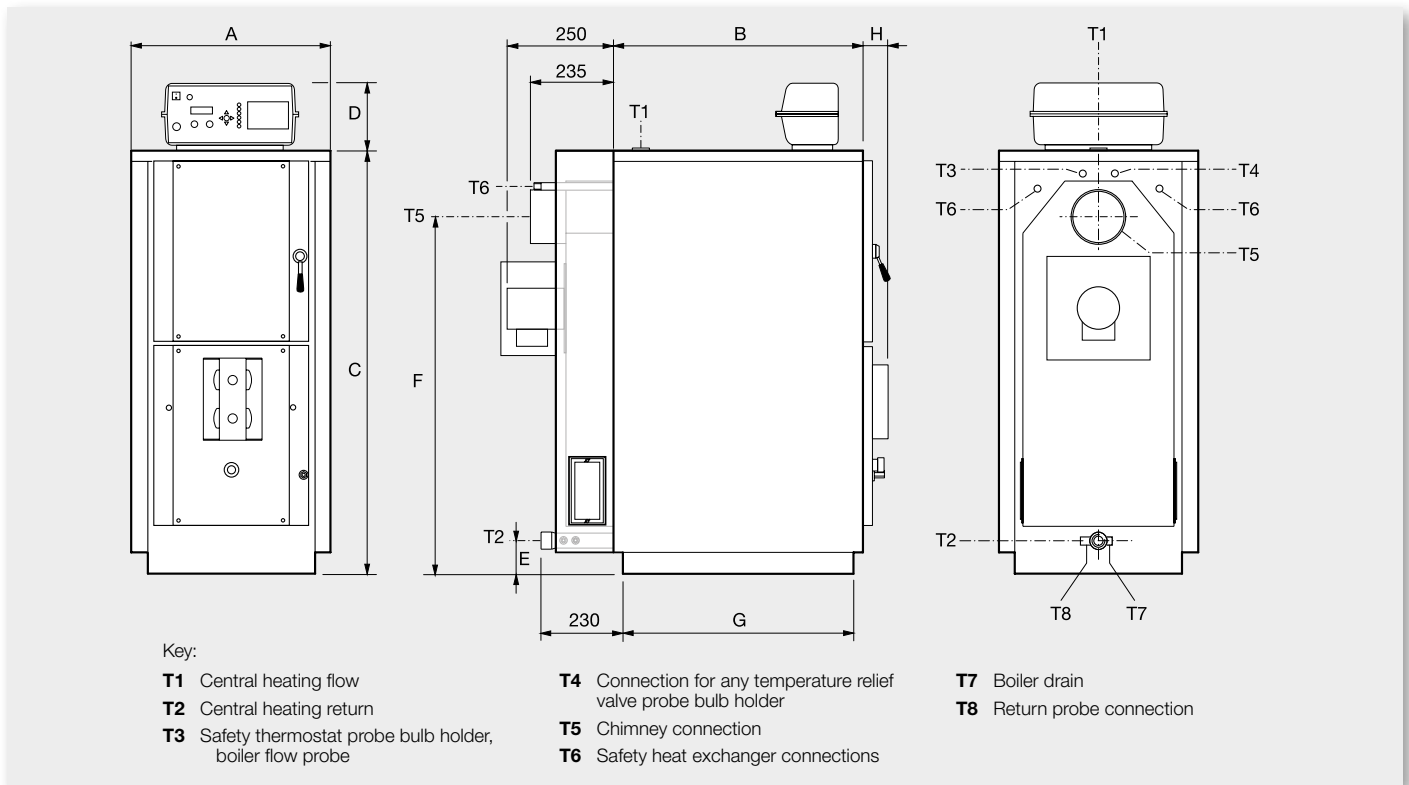

FIREX 2S	A mm	B mm	C mm	D mm	E mm	F mm	G mm	H mm	T1 UNI ISO 228/1	T2 UNI ISO 228/1	T3 UNI ISO 228/1	T4 UNI ISO 228/1	T5 Ø mm	T6 UNI ISO 228/1	T7 UNI ISO 228/1	T8 UNI ISO 228/1
34	510	680	1230	190	78	1025	628	65	G 1 ¼	G 1 ¼	G ½	G ½	150	G ½	G ½	G ½
45	610	680	1380	190	81	1150	628	65	G 1 ½	G 1 ½	G ½	G ½	200	G ½	G ½	G ½
55	610	880	1380	190	81	1150	828	65	G 1 ½	G 1 ½	G ½	G ½	200	G ½	G ½	G ½

FIREX 2S		34	45	55
NOMINAL OUTPUT	kW	30,6	40,1	49,1
FURNACE OUTPUT	kW	34,2	45	55,2
SEASON EFFICIENCY CLASS IN HEATING MODE		A+	A+	A+
EFFICIENCY	%	89,5	89,1	89,1
BOILER CLASS ACCORDING TO EN 303-5:2012		5	5	5
MAX OPERATING PRESSURE	bar	3	3	3
WOOD STORAGE VOLUME	l	108	160	218
LOG LENGTH	cm	50	50	70
NOMINAL LOADING FLUE TEMPERATURE	°C	171	177	178
CHIMNEY CONNECTION	mm	150	200	200
BOILER WATER CONTENT	l	59	71	93
MAXIMUM OUTPUT	W	146	146	146
CO @ 13% O ₂	mg/Nm ³	262	341	267
NOx @ 13% O ₂	mg/Nm ³	131	133	137
Hc @ 13% O ₂	mg/Nm ³	0,8	7,3	8
Dust 13% O ₂	mg/Nm ³	19	18	19
EMPTY BOILER WEIGHT	kg	363	475	623